

# Model: WRS81-30T

Electric Powered Walkie/Rider Reach Stacker

Capacity: 3,000 lbs

# LIFTSTAR™

Make Your Job Easier

LIFTSTAR™ engineered with a compact body and loading design that enhance maneuverability in confined spaces and congested areas.

## Standard Features

- ★ LIFTSTAR designed Electric Power Steering (EPS).
- ★ 24V electrical system, AC drive motor and DC lifting motor
- ★ Regenerative travel brake
- ★ Battery discharge indicator with hour meter
- ★ Polyurethane wheels
- ★ Curtis 1230/200A Controller
- ★ Key switch to control user access

## Safety

- ★ Automatic speed reduction technology for sharp corner turns
- ★ Emergency reversing button
- ★ Electromagnetic braking initiated by the emergency stop button acts on the drive motor proportional to the load carried

## Ergonomics

- ★ Tiller head designed for maximum operator comfort and control
- ★ Controls positioned to allow either hand operation
- ★ EPS system provides optimum directional control at any speed

## Total Drive System

- ★ Equipped with powerful AC drive system
- ★ External encoder for easy replacement
- ★ Precise positioning of loads
- ★ High torque
- ★ Brushless, regenerative brake



**CORNERING  
SPEED CONTROL**  
Automatically decelerates  
and accelerates  
based on real-time  
operating conditions



[www.hmhservices.com](http://www.hmhservices.com)

call 724-696-2365

Information and specifications provided are based on product design at the time of publication are subject to change without notice. 12/14

# Model: WRS81-30T

## Electric Powered Walkie/Rider Reach Stacker



Make Your Job Easier

MODEL SPECIFICATIONS	WRS81-30T
Q Capacity	3000 lb
C Load Center	24"
Operator Type	Walkie (optional Ride-on)
H Maximum Fork Lifting Height	69.3" / 181.1' / 196.9'
H <sub>7</sub> Lowered Height of Fork	1"
B <sub>1</sub> Standard Fork Width	Adjustable maximum 26"
L Fork Length	42"
Fork Thickness	1.6"
E Fork Width	3.9"
L <sub>3</sub> Reach Distance	16.9"
Fork Tilting Degree (forward/backward)	3/5
Wa Minimum Turning Radius	63" (78.7")
Ast Min Aisle Width for Pallets (800 X 1200):	106.1" (123.6)
Ast Min Aisle Width for Pallets (1000 X 1200):	108.1" (125.4)
H <sub>6</sub> Minimum Ground Clearance	2.4"
Travel Speed (full load / no load)	3.1 / 3.1 mph
Lifting Speed (full load / no load)	5.1 / 6.7 in/s
Lowering Speed (full load / no load)	9 / 5.1 in/s
Gradeability (full load / no load)	7.5% / 11.5%
L <sub>1</sub> Overall Length Including Forks	95.7 (110.2)
B Overall Width	42.6"
H <sub>2</sub> Mast Extend Height	203.9" / 215.7" / 231.5"
H <sub>1</sub> Mast Lower Height	84.3" / 89.0" / 96.9 "
Wheel type	Polyurethane
Wheel Quantity	1 Drive / 2 Loading
D <sub>2</sub> Dimension of Drive Wheel	9.8" X 3.0"
Y Wheel Base	53.4"
Weight w/o Battery	4,301 lb
Weight with Battery	4,840 lb
Voltage	24 V
Battery Capacity / Type	280Ah / Industrial
Controller	Curtis 1230/200A

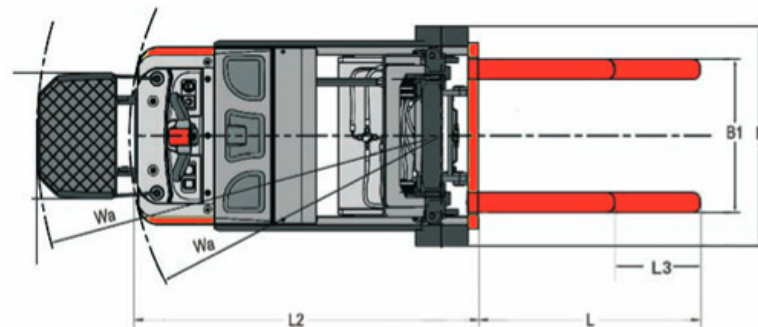
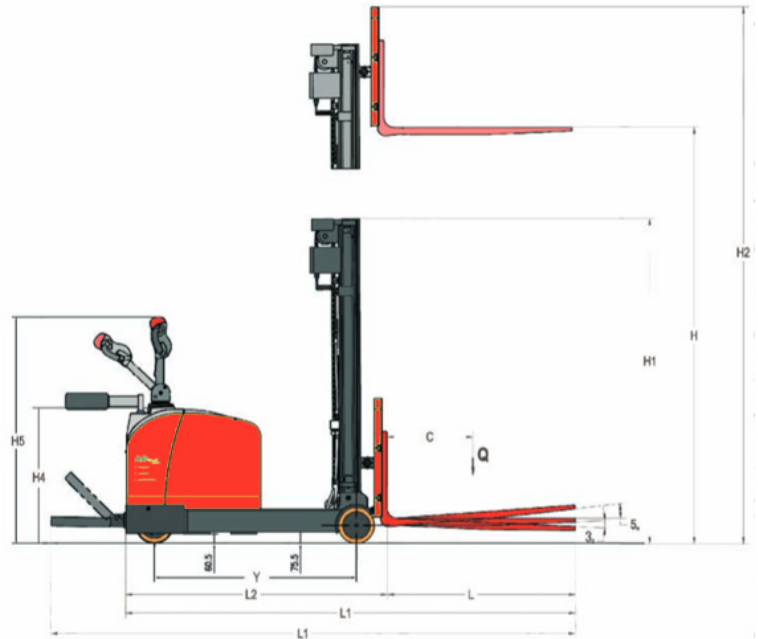

### Options

- ★ Load Back Rest 36" Tall
- ★ Load Back Rest 60" Tall
- ★ Side Shifter
- ★ Cold Conditioning
  - ★ Continuous use 32°F to 120°F
  - ★ Intermittent use below 32°F
- ★ Fork lengths: 36" / 42" / 48" / 54"



[www.hmhservices.com](http://www.hmhservices.com)  
call 724-696-2365

Information and specifications provided are based on product design at the time of publication are subject to change without notice. 12/14