

Model: WP52-60/80
Heavy Duty Electric Pallet Truck
Capacity: 6,000 lbs / 8,000 lbs



Make Your Job Easier

LIFTSTAR™ Heavy Duty Electric Pallet Trucks are the durable, innovative and economical material handling solution.

Moonwalk

Feature allows the user to operate the unit from the side, allowing for better visibility and requiring less space when working in narrow aisles

Quiet Night

Design reduces lifting noise to less than 60 dB, which is the lowest in the industry

Standard Features

- ★ LIFTSTAR designed Electric Power Steering (EPS).
- ★ 24V electrical system, 3 KW AC drive motor and DC lifting motor with Curtis 1234 controller
- ★ Regenerative brake
- ★ Battery discharge indicator with hour meter
- ★ Polyurethane wheels
- ★ Cold Conditioning
 - ★ Continuous use 32°F to 120°F
 - ★ Intermittent use below 32°F
- ★ Key switch to control user access

Safety

- ★ Automatic speed reduction technology for sharp corner turns
- ★ Emergency reversing button
- ★ Electromagnetic braking initiated by the emergency stop button acts on the drive motor proportional to the load carried

Ergonomics

- ★ Tiller head designed for maximum operator comfort and control
- ★ Deep and wide storage compartments for work gloves, writing utensils, etc.
- ★ Thumb control travel function

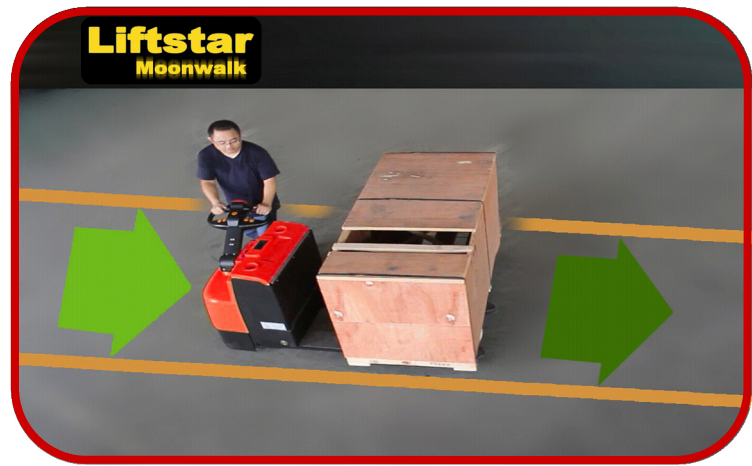
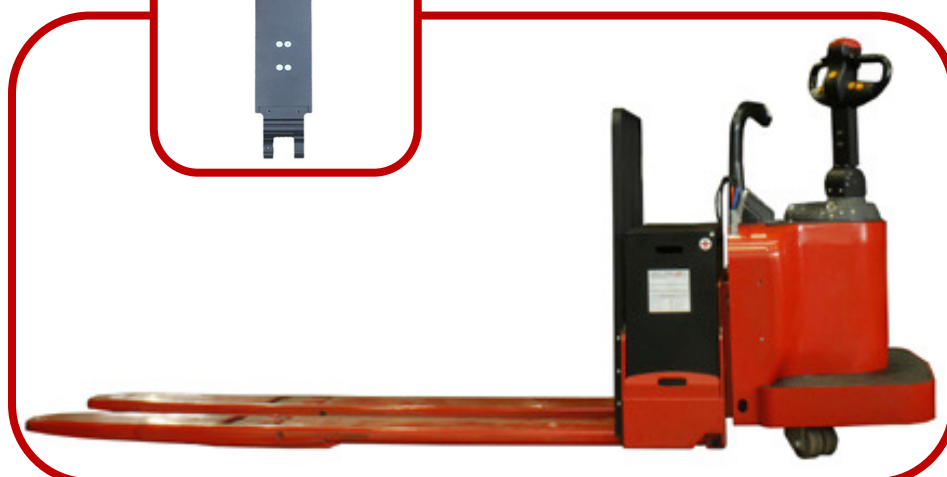

www.hmhservices.com
call 724-696-2365

Information and specifications provided are based on product design at the time of publication are subject to change without notice. 12/14

Model: WP52-60/80

Heavy Duty Electric Pallet Truck



Make Your Job Easier

Model	WP52-60/80
Q Load Capacity	6000/8000 lb
C Load Center	24"
Y Wheel Base	63"
Operating Type	Rider (Single Pallet)
Electric Power Steering (EPS)	Standard Equipped
H ₂ Minimum Fork Lowered Height	3.35"
H Maximum Fork Lifting Height	9.06"
B ₁ Overall Fork Width	26.77"
L Fork Length	48"/54"/60"
E Fork Width	9.06"
S Fork Thickness	2.36"
L ₁ Overall Length	93.4"
B Overall Width	36.6"
L ₂ Rear Body Length	45.4"
H ₅ Overall Height (with handle)	60.47"
Overall Height (without handle)	50.39"
Wa Minimum Turning Radius	86.2"
Ast Minimum Aisle Width for Pallets 48x48	99.84"
Travel Speed (full load / no load)	7/9 MPH
Max Lifting Speed (full load / no load)	1.18/1.38 in/s
Max Lowering Speed (full load / no load)	1.77/1.57 in/s
Gradeability (full load / no load)	5% / 7%
Battery Weight	771 lbs
Service Weight with Battery	2299 lbs
Wheels Type	PU
Wheel Qty. (Driving/Balance/Loading Wheel)	1/4/2
Driving Wheel Size	9"x3.66"
Loading Wheel Size	3.3"x6.1"
Balance Wheel Size	4.53"x2.17"
Drive Motor	AC 4.2
Lifting Motor	DC 2
Battery Voltage/Capacity	24/350 V/Ah
Brake	Electromagnetic/Regenerative
Controller	Curtis 1243

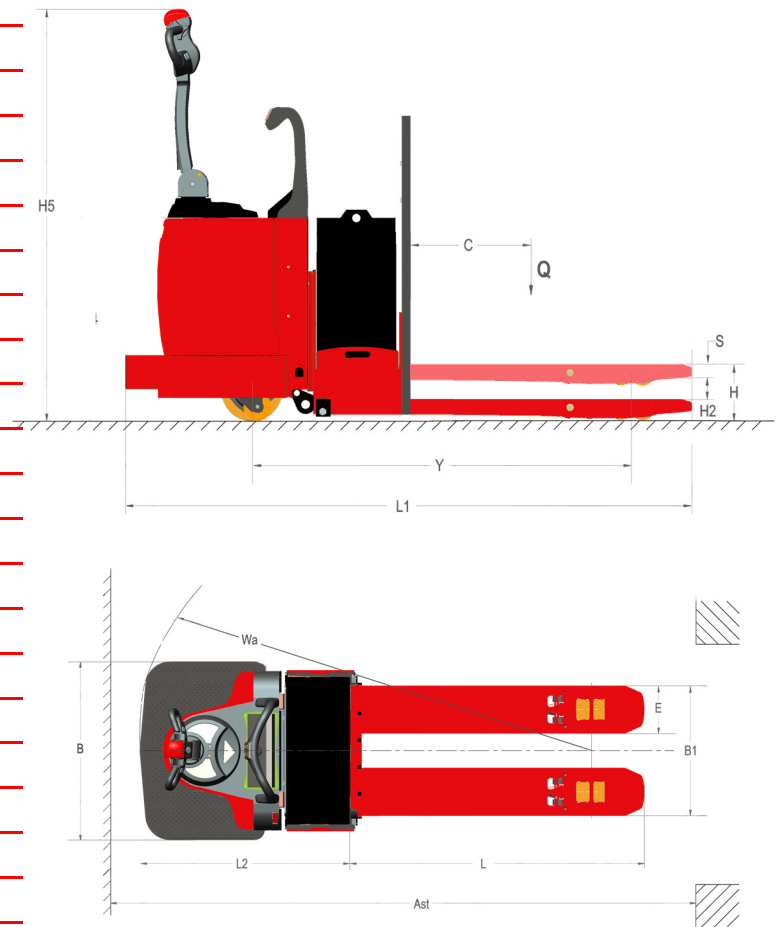

Options

- ★ Load Back Rest 48" Tall
- ★ Load Back Rest 60" Tall
- ★ Cold Conditioning
 - ★ Continuous use 32°F to 120°F
 - ★ Intermittent use below 32°F
- ★ Battery Options
 - ★ 350Ah Lead Acid Battery

DURABLE ★ INNOVATIVE ★ ECONOMICAL



www.hmhservices.com
call 724-696-2365

Information and specifications provided are based on product design at the time of publication are subject to change without notice.
12/14