

## Model: WRS85-30

Heavy Duty Electric Reach Stacker

Capacity: 3,000 lbs

# STAXX

**STAXX™ Engineered with a compact body and loading design that enhance maneuverability in confined spaces and congested areas.**

### Standard Features

- ✘ STAXX designed Electric Power Steering (EPS).
- ✘ 24V electrical system, AC drive motor and DC lifting motor
- ✘ Battery discharge indicator with hour meter
- ✘ Polyurethane wheels
- ✘ Curtis 1230/200A Controller
- ✘ Key switch to control user access

### Safety

- ✘ Automatic speed reduction technology for sharp corner turns
- ✘ Emergency reversing button
- ✘ Electromagnetic braking initiated by the emergency stop button acts on the drive motor proportional to the load carried

### Ergonomics

- ✘ Tiller head designed for maximum operator comfort and control
- ✘ Controls positioned to allow either hand operation
- ✘ EPS system provides optimum directional control at any speed

### Total Drive System

- ✘ Equipped with powerful AC drive system
- ✘ External encoder for easy replacement
- ✘ Precise positioning of loads
- ✘ High torque
- ✘ Brushless, regenerative brake



[www.hmhservices.com](http://www.hmhservices.com)

call 724-696-2365

Information and specifications provided are based on product design at the time of publication are subject to change without notice. 06/17

# Model: WRS85-30

## Heavy Duty Electric Reach Stacker



MODEL SPECIFICATIONS	WRS85-30
Mast Type	Triplex
Q Capacity	3000 lb
C Load Center	24"
Operator Type	Walkie
Electric Power Steering	Standard
H Maximum Fork Lifting Height	142"/157"/177"/197"/208"/217"
H <sub>7</sub> Lowered Height of Fork	2.17"
B <sub>1</sub> Standard Fork Width	Adjustable maximum 29.72"
L Fork Length	42"
Fork Thickness	1.6"
E Fork Width	3.9"
L <sub>3</sub> Reach Distance	24"
Fork Tilting Degree (forward/backward)	4/3
Wa Minimum Turning Radius	62"
Ast Min Aisle Width for Pallets (800 X 1200):	93.9"
Ast Min Aisle Width for Pallets (1000 X 1200):	97"
H <sub>6</sub> Minimum Ground Clearance	1.9"
Travel Speed (full load / no load)	2.2 / 3 mph
Lifting Speed (full load / no load)	5.1 / 9.1 in/s
Lowering Speed (full load / no load)	9.1 / 5.1 in/s
Gradeability (full load / no load)	5% / 8%
L <sub>1</sub> Overall Length Including Forks	87.6"
L <sub>2</sub> Rear Body Length	46.5"
B Overall Width	56.3"
B <sub>2</sub> Rear Body Width	36"
B <sub>4</sub> Straddle Leg ID	42"
H <sub>2</sub> Mast Extend Height	188"/204"/224"/244"/255"/263"
H <sub>1</sub> Mast Lower Height	77"/82"/89"/95"/99"/102"
Wheel Type	Polyurethane
Wheel Quantity	1 Drive / 4 Loading
Y Wheel Base	58"
Weight w/o Battery	4,387 lb
Weight with Battery	5,049 lb
Voltage	24 V
Battery Capacity / Type	345Ah / Industrial
Controller	Curtis 1230/200A

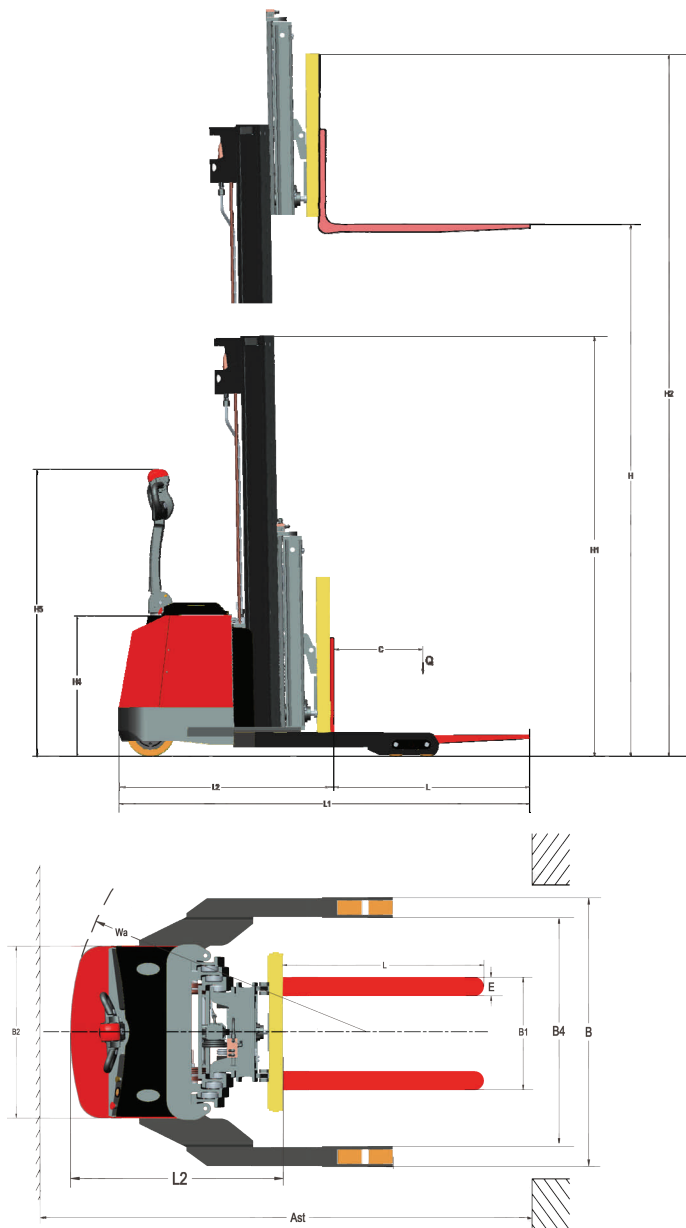

### Options

- ✘ Load Back Rest 36" Tall
- ✘ Load Back Rest 60" Tall
- ✘ Side Shifter
- ✘ Cold Conditioning
  - ✘ Continuous use 32°F to 120°F
  - ✘ Intermittent use below 32°F
- ✘ Fork lengths: 36" / 42" / 48" / 54"

**DURABLE. INNOVATIVE. ECONOMICAL.**



[www.hmhservices.com](http://www.hmhservices.com)  
call 724-696-2365

Information and specifications provided are based on product design at the time of publication are subject to change without notice. 06/17